



# CL12 SITE SPECIFICATIONS

- **BAY HEIGHT:** 14' minimum (for standard model)
- **BAY WIDTH:** 14' recommended
- **BAY DEPTH:** 24' recommended
- **POWER REQ.:** 208-230v Single Phase\*, 30-amp breaker
- **MIN. CONCRETE SPEC:** 4" thick, reinforced, free from cracks/seams, rated at 3500+ psi, cured at least 28 days

Model Number	CL12-LC	CL12-LC-QC-DPC	CL12	CL12-1	CL12-2	CL12-QC-DPC
Lifting Capacity	12,000 lbs.					
Lifting Configuration	Symmetric					
Arms	3-stage front/3-stage rear					
Rise Height <sup>1</sup>	80.25"		84.75"			
Overall Height	11'11"		13'8" / 13'2" <sup>2</sup>	14'8" / 14'2" <sup>2</sup>	15'8" / 15'2" <sup>2</sup>	13'8" / 13'2" <sup>2</sup>
Overall Width	142"					
Drive-Thru Clearance	103.5"					
Floor to Overhead Switch	136"		157"	169"	181"	157"
Arm Reach (Min.)	27.5"					
Arm Reach (Max.)	59"					
Screw Pad Height <sup>2</sup>	5" / 12.625" (includes 6" stack adapter)					
Inside Columns	114.5"					
Motor / Voltage <sup>3</sup>	2HP, 208v-230v, 60Hz, 1Ph	3HP, 208v-230v, 60Hz, 1Ph	2HP, 208v-230v, 60Hz, 1Ph			3HP, 208v-230v, 60Hz, 1Ph
Speed of Rise	60 s	38 s	63 s		40 s	
Ceiling Height Required	12'		13' 9"	14' 9"	15' 9"	13'9"
ALI/ETL Certified	√					
Colors Available						

## SERVICE BAY LAYOUT

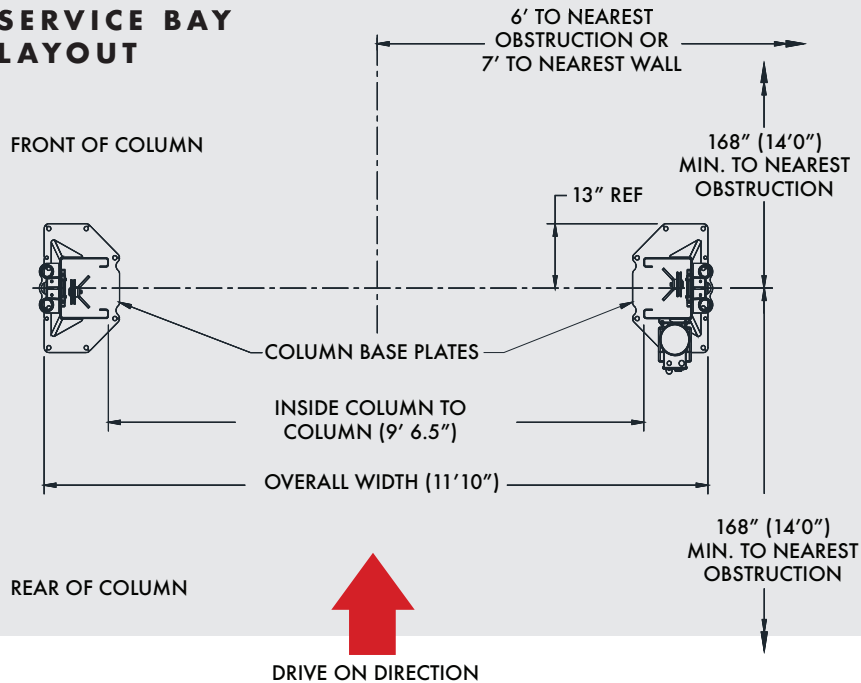

\*3-phase upgrade is available for purchase

<sup>1</sup>Rise height is measured with superstructure in highest position.

<sup>2</sup>Height can be adjusted as much as 6" down to allow for ceiling obstruction