

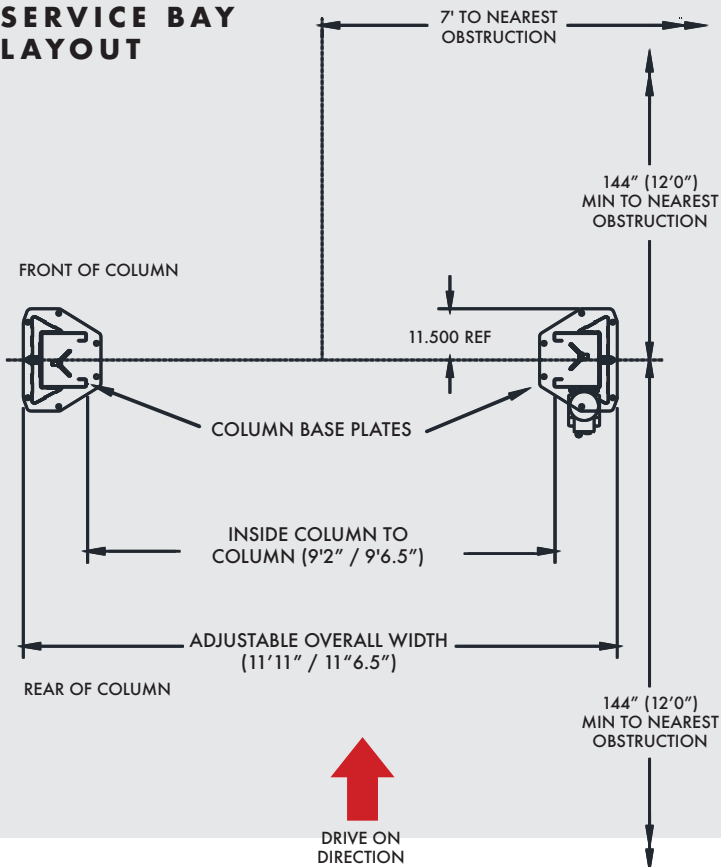

## SERVICE BAY LAYOUT



\*3-phase upgrade is available for purchase

## CL10V3 SITE SPECIFICATIONS

- **BAY HEIGHT:** 12' minimum
- **BAY WIDTH:** 12' recommended
- **BAY DEPTH:** 24' recommended
- **POWER REQ.:** 208-230v Single Phase\*, 30-amp breaker
- **MIN. CONCRETE SPEC:** 4" thick, reinforced, free from cracks/seams, rated at 3500+ psi, cured at least 28 days

Model Number	CL10V3	CL10V3-DPC	CL10V3-QC	CL10V3-DPC-QC
Lifting Capacity	10,000 lbs.			
Lifting Configuration	Versymmetric (Symmetric & Asymmetric)			
Arms	3-stage front/3-stage rear			
Rise Height	74.125"			
Overall Height	140"			
Overall Height (Cylinder Extended)	143"			
Overall Width	138.5" / 143"			
Drive-Thru Clearance	100" / 104.5"			
Floor to Overhead Switch	134.5"			
Front Arm Reach	20" / 42"			
Rear Arm Reach	37.625" / 60"			
Screw Pad Height	3.875" / 6.125"			
Inside Columns	110" / 114.5"			
Motor / Voltage	2HP, 208v-230v, 60Hz, 1Ph			
Speed of Rise	38 s		27 s	
Ceiling Height Required	12'			
ALI/ETL Certified	√	√	√	√
2' Height Extension Available	√	√	√	√
3' Height Extension Available	√	√	√	√
Featuring Quick Cycle	-	-	√	√
Featuring Dual Pendant Controls	-	√	-	√
Colors Available				